

## Description

The AYRLITE ACP Extrusion Suite consists of 12 profiles to suit 10 mm, 20 mm and 30 mm panels.

AYRLITE honeycomb panels are positioned within the extrusion (refer to the extrusion illustration). Assembly of the AYRLITE panel and AYRLITE extrusion is made using polyurethane adhesive eg Sikaflex 291. With the 20 mm Corner Post (ACP2853), End Cap (ACP2855) and Joiner (ACP2856) the honeycomb panel edges are routed with a slot to accept the extrusion tongue.

Router cutters and polyurethane adhesive are also available from Ayres Composite Panels.

A CD is available, showing assembly techniques (contact Ayres Composite Panels for details).

## Features

- Aluminium alloy 6063 T5.
- Suits 10 mm (0.39 in), 20 mm (0.79 in) and 30 mm (1.18 in) panels.
- Standard extrusion length is 2400 mm (94 in), although lengths up to 4900 mm (189 in) are available.
- Clear anodised finish, 10 µm thickness.

## Safety

As with cutting operations on most materials, avoid inhalation and eye contact with machining dust. Wear protective equipment such as ear defenders and safety glasses during any cutting operations. Use machine guards. Wear gloves to avoid cuts. Wash hands before eating, drinking or smoking and after finishing work.

## Weights

### 10mm (0.39 in) Extrusions

ACP8529 Corner	0.36 kg/m (0.25 lb/ft)
ACP8587 Door Jamb	0.10 kg/m (0.07 lb/ft)
ACP131 End Cap	0.08 kg/m (0.06 lb/ft)
ACP130 Joiner	0.17 kg/m (0.12 lb/ft)

### 20mm (0.79 in) Extrusions

ACP2853 Corner	0.47 kg/m (0.32 lb/ft)
ACP2854 Door Trim	0.16 kg/m (0.11 lb/ft)
ACP2855 End Cap	0.17 kg/m (0.12 lb/ft)
ACP2856 Joiner	0.24 kg/m (0.17 lb/ft)
ACP2857 Channel	0.17 kg/m (0.12 lb/ft)
ACP8208 Corner Trim	0.14 kg/m (0.10 lb/ft)
ACP8667 Shelf Edge	0.27 kg/m (0.19 lb/ft)

### 30mm (1.18 in) Extrusions

ACP8629 Table Edge	0.21 kg/m (0.15 lb/ft)
--------------------	------------------------

10mm (0.39 in) Extrusions

CAD drawings available from Ayres Composite Panels

Clear Anodised Aluminium Extrusion Suite  
For 10 mm (0.39 in) Honeycomb Sandwich Panels

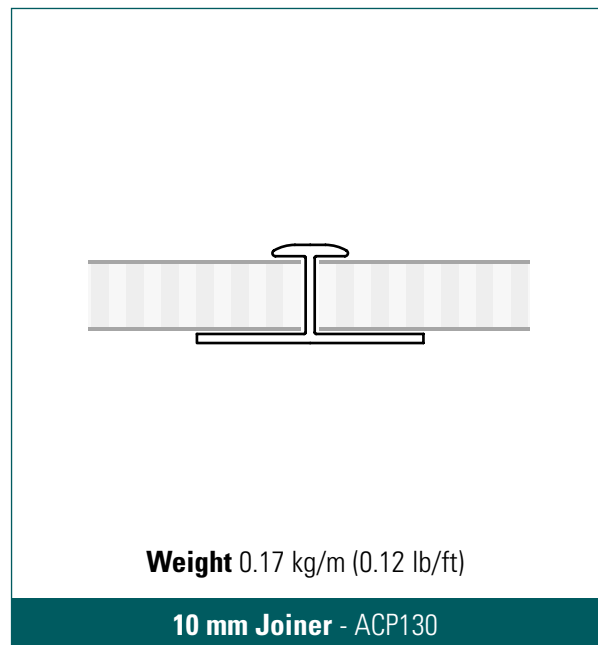
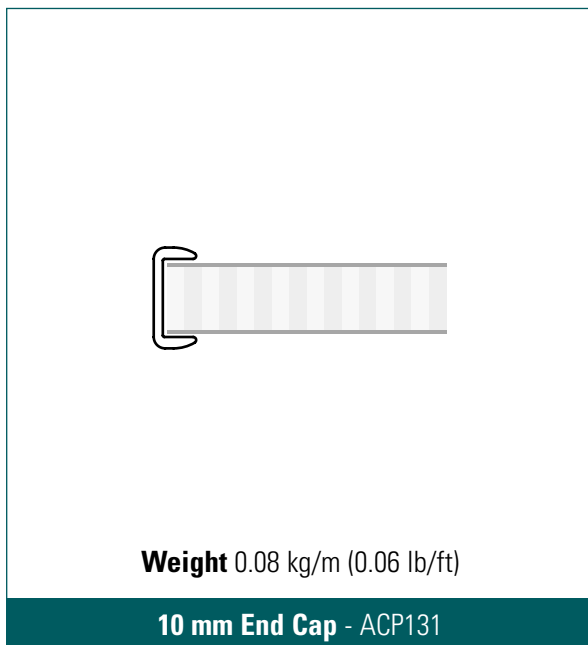
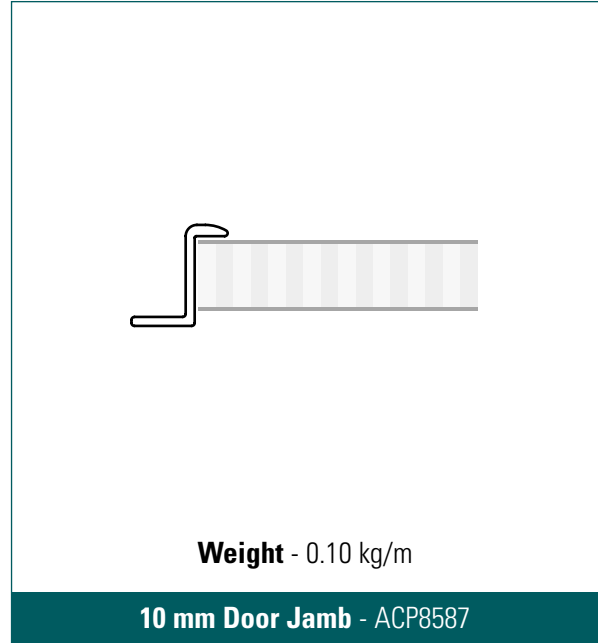
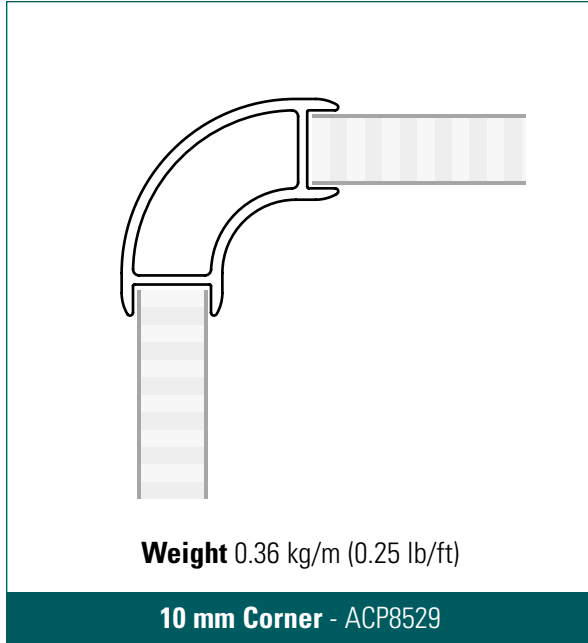

20mm (0.79 in) Extrusions

CAD drawings available from Ayres Composite Panels

Clear Anodised Aluminium Extrusion Suite  
For 20 mm Honeycomb Sandwich Panels

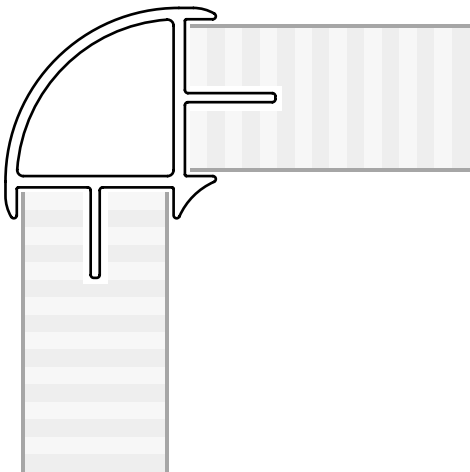

**Weight** 0.47 kg/m (0.32 lb/ft)

**20 mm Corner - ACP2853**

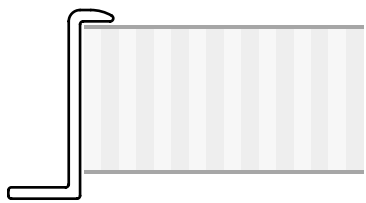

**Weight** 0.16 kg/m (0.11 lb/ft)

**20 mm Door Trim - ACP2854**

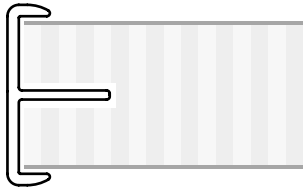

**Weight** 0.17 kg/m (0.12 lb/ft)

**20 mm End Cap - ACP2855**

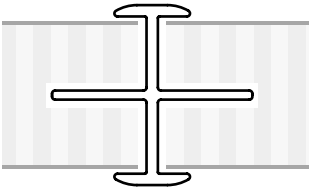

**Weight** 0.24 kg/m (0.17 lb/ft)

**20 mm Joiner - ACP2856**



**Weight** 0.17 kg/m (0.12 lb/ft)

**20 mm Channel - ACP2857**

**20 mm (0.79 in) Extrusions**

CAD drawings available from Ayres Composite Panels

Clear Anodised Aluminium Extrusion Suite  
For 20 mm (0.79 in) Honeycomb Sandwich Panels



**Weight** 0.27 kg/m (0.19 lb/ft)

**20 mm Shelf Edge - ACP8667**

\* Can also be used with other panel thicknesses.

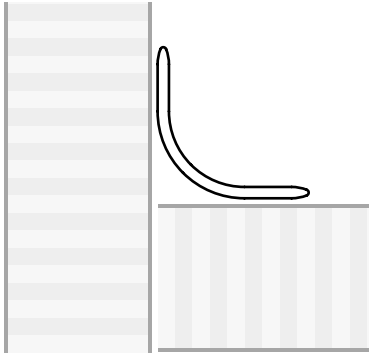

**Weight** 0.14 kg/m (0.10 lb/ft)

**\* 20 mm Corner Trim - ACP8208**

**30 mm (1.18 in) Extrusions**

CAD drawings available from Ayres Composite Panels

Clear Anodised Aluminium Extrusion Suite  
For 30 mm (1.18 in) Honeycomb Sandwich Panels

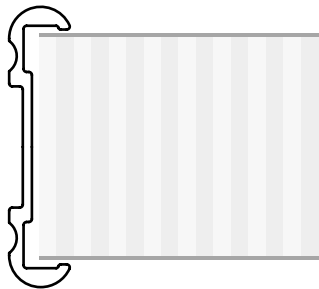

**Weight** 0.21 kg/m (0.15 lb/ft)

**30 mm Table Edge - ACP8629**



**Ayres Composite Panels Pty Ltd**  
ABN 84 071 540 568

**Asia-Pacific**  
asia-pacific@ayrescom.com  
**Europe**  
europe@ayrescom.com  
**USA**  
usa@ayrescom.com

**www.ayrescom.com**

*Lighten Up!*